

Why Should I Care?

The evolution of the Internet to IPv6 will directly affect enterprise and public sector customers because they will have to communicate with their customers, partners, suppliers, students, and constituents over an IPv6 network.

In order to ensure business continuity, future growth, and equitable access to information for all constituents, organizations need to carefully plan for coexistence between IPv4 and IPv6.

Some endpoints may need to convert to IPv6 only before an organization is ready to convert its entire network or all of its applications to support IPv6. The organization may also have dual-stack-capable endpoints that prefer to use IPv6.

Who Needs NAT 64 Support?

- Organizations with IPv6-enabled endpoints on their networks that have not already converted all of their data center servers and IT applications to support IPv6, but want or need to take advantage of the IPv6 capability of those endpoints, need Network Address Translation 64 (NAT 64) support. These IPv6-enabled endpoints may be owned and controlled by the organization, they may be employee-provided, or they may be guest devices such as those owned by students on a college campus.

What Is It?

Stateless NAT 64 provides address family translation services from IPv6 to IPv4 and from IPv4 to IPv6. This technology is one of several IPv4-to-IPv6 migration and coexistence technologies available from Cisco.

Benefits

It allows organizations to de-couple the migration of endpoints and applications to IPv6, reducing the need to force coordination in IPv6 plans between the desktop, network, and application IT teams within an organization. It could also allow a delay in conversion of servers and applications to support IPv6 until they are upgraded for other reasons, thus reducing the specific costs associated with supporting IPv6.

Cisco Solution for IPv6 Endpoints on an IPv6 or Dual stack Network with IPv4 Applications on an IPv4 Network

The Cisco® ASR 1000 Aggregation Services Routers provides the stateless NAT 64 function. See Figure 1 "IPv6 endpoints with IPv4 applications"

Solution Components

- Cisco ASR 1000 running Cisco IOS® Software
- Cisco (or other vendor) switches and routers running dual-stack IPv6 or IPv4 or IPv6 over IPv4 tunnels
- Dynamic Host Configuration Protocol (DHCP) server to allocate IPv6 addresses to IPv6 endpoints from a restricted IPv6 address range
or
A Domain Name System 64 (DNS64) server; in this configuration the restriction of a restricted IPv6 address range is eliminated

This solution can be used with either IPv4 or IPv6 dual stack or IPv6 tunnels over a network that still includes some IPv4-only network elements, but dual stack is recommended.

Figure 1. IPv6 Endpoints with IPv4 Applications

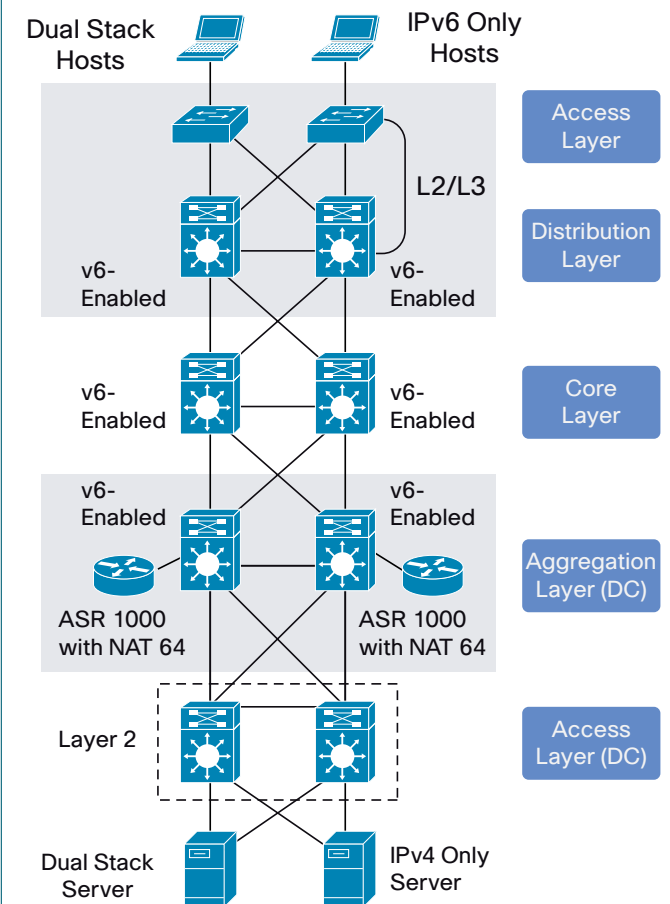

Cisco Solution for IPv6 Network Connected to IPv4 Internet

The Cisco ASR 1000 provides the stateless NAT 64 function for this solution. See Figure 2 "IPv6 Network Connected to IPv4 Internet"

Solution Components

- Cisco ASR 1000 running Cisco IOS Software
- Cisco (or other vendor) switches and routers running dual-stack IPv6 or IPv4 or IPv6 over IPv4 tunnels

With this solution an organization that wants to run IPv6 on a site or campus can still provide access to and from the IPv4 Internet. One important restriction of this solution is that it requires each host in the IPv6 network that needs to communicate with the IPv4 Internet to have a routable IPv4 address at the Cisco ASR 1000, so it does not currently solve the address exhaustion problem. This solution is useful for customers who want to use IPv6 on a site or campus to reduce the operating expenses (OpEx) of running IPv6 tunnels or IPv6 or IPv4 dual-stack solutions in that site or campus.

Figure 2. IPv6 Network Connected to IPv4 Internet

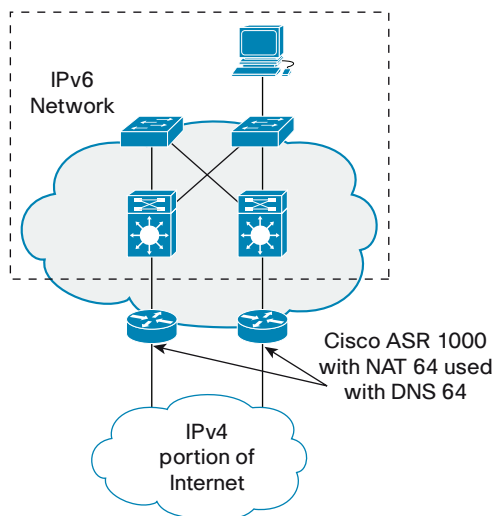

For additional information about the capabilities and limitations of these solutions, refer to the Cisco technical document for stateless NAT 64.

Cisco IPv6 Services can help customers plan for introduction of the stateless NAT 64 translation into the network, design an effective solution for both IPv6 and IPv4, and provide implementation support of the stateless NAT 64 translation.

Cisco IPv6 Services will provide a look design for those endpoints that need NAT 64 translation, while also designing optimal performance for those endpoints that don't need NAT 64 translation. Providing designs, test plan templates and consulting support allows our customers to proactively budget time, money and resources for this solution.

Further Information

For more information about Cisco IPv6 products, solutions, and services, visit www.cisco.com/go/ipv6.