

## Introduction to Cisco IOS® NetFlow

Last updated: October 2007

Successfully delivering mission critical, performance sensitive services and applications with NetFlow

NetFlow is an embedded instrumentation within Cisco IOS Software to characterize network operation. Visibility into the network is an indispensable tool for IT professionals. In response to new requirements and pressures, network operators are finding it critical to understand how the network is behaving including:

- Application and network usage
- Network productivity and utilization of network resources
- The impact of changes to the network
- Network anomaly and security vulnerabilities
- Long term compliance issues

Cisco IOS NetFlow fulfills those needs, creating an environment where administrators have the tools to understand who, what, when, where, and how network traffic is flowing. When the network behavior is understood, business process will improve and an audit trail of how the network is utilized is available. This increased awareness reduces vulnerability of the network as related to outage and allows efficient operation of the network. Improvements in network operation lower costs and drives higher business revenues by better utilization of the network infrastructure.

Enterprises depend heavily on Cisco IOS NetFlow in order to meet their business objectives including Cisco IT: "As converged networks and IP telephony become more prevalent, the ability to characterize traffic on the network, both for capacity planning and anomaly detection, will become even more critical." Roland Dobbins, Cisco IT Network Engineer.

Read more information on how Cisco IT uses NetFlow:

- NetFlow gives Network Managers a Detailed View of Application Flows on the Network  
[http://www.cisco.com/application/pdf/en/us/quest/products/ps6601/c1042/cdccont\\_0900aec\\_d80311fc2.pdf](http://www.cisco.com/application/pdf/en/us/quest/products/ps6601/c1042/cdccont_0900aec_d80311fc2.pdf)

This white paper illustrates the importance of NetFlow and demonstrates how NetFlow can be used by Enterprises, Small and Medium-sized Businesses (SMBs), and Channel Partners to meet critical network challenges. It is a basic overview of how NetFlow works and produces data and reporting solutions.

## Increasing Importance of Network Awareness

### Traditional SNMP Performance Monitoring

Traditionally customers relied almost exclusively on Simple Network Management Protocol (SNMP) to monitor bandwidth. Although SNMP facilitates capacity planning, it does little to characterize traffic applications and patterns, essential for understanding how well the network supports the business. A more granular understanding of how bandwidth is being used is extremely important in IP networks today. Packet and byte interface counters are useful but understanding which IP addresses are the source and destination of traffic and which applications are generating the traffic is invaluable.

### NetFlow Based Network Awareness

The ability to characterize IP traffic and understand how and where it flows is critical for network availability, performance and troubleshooting. Monitoring IP traffic flows facilitates more accurate capacity planning and ensures that resources are used appropriately in support of organizational goals. It helps IT determine where to apply Quality of Service (QoS), optimize resource usage and it plays a vital role in network security to detect Denial-of-Service (DoS) attacks, network-propagated worms, and other undesirable network events.

NetFlow facilitates solutions to many common problems encountered by IT professionals.

- **Analyze new applications and their network impact**  
Identify new application network loads such as VoIP or remote site additions.
- **Reduction in peak WAN traffic**  
Use NetFlow statistics to measure WAN traffic improvement from application-policy changes; understand who is utilizing the network and the network top talkers.
- **Troubleshooting and understanding network pain points**  
Diagnose slow network performance, bandwidth hogs and bandwidth utilization quickly with command line interface or reporting tools.
- **Detection of unauthorized WAN traffic**  
Avoid costly upgrades by identifying the applications causing congestion.
- **Security and anomaly detection**  
NetFlow can be used for anomaly detection and worm diagnosis along with applications such as Cisco CS-Mars.
- **Validation of QoS parameters**  
Confirm that appropriate bandwidth has been allocated to each Class of Service (CoS) and that no CoS is over- or under-subscribed.

## How does NetFlow give you network information?

### What is an IP Flow?

Each packet that is forwarded within a router or switch is examined for a set of IP packet attributes. These attributes are the IP packet identity or fingerprint of the packet and determine if the packet is unique or similar to other packets.

Traditionally, an IP Flow is based on a set of 5 and up to 7 IP packet attributes.

IP Packet attributes used by NetFlow:

- IP source address
- IP destination address
- Source port
- Destination port
- Layer 3 protocol type
- Class of Service
- Router or switch interface

All packets with the same source/destination IP address, source/destination ports, protocol interface and class of service are grouped into a flow and then packets and bytes are tallied. This methodology of fingerprinting or determining a flow is scalable because a large amount of network information is condensed into a database of NetFlow information called the NetFlow cache.

**Figure 1.** Creating a flow in the NetFlow cache

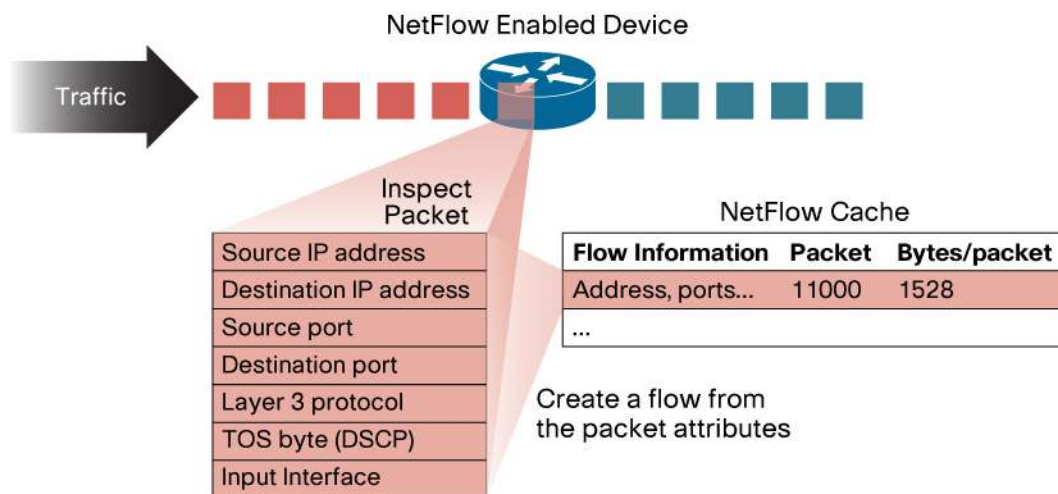

This flow information is extremely useful for understanding network behavior

- Source address allows the understanding of who is originating the traffic
- Destination address tells who is receiving the traffic
- Ports characterize the application utilizing the traffic
- Class of service examines the priority of the traffic
- The device interface tells how traffic is being utilized by the network device
- Tallied packets and bytes show the amount of traffic

Additional information added to a flow includes

- Flow timestamps to understand the life of a flow; timestamps are useful for calculating packets and bytes per second
- Next hop IP addresses including BGP routing Autonomous Systems (AS)
- Subnet mask for the source and destination addresses to calculate prefixes
- TCP flags to examine TCP handshakes

### **How to Access the Data Produced by NetFlow?**

There are two primary methods to access NetFlow data: the Command Line Interface (CLI) with show commands or utilizing an application reporting tool. If you are interested in an immediate view of what is happening in your network, the CLI can be used. NetFlow CLI is very useful for troubleshooting.

The other choice is to export NetFlow to a reporting server or what is called the “NetFlow collector”. The NetFlow collector has the job of assembling and understanding the exported flows and combining or aggregating them to produce the valuable reports used for traffic and security analysis. NetFlow export, unlike SNMP polling, pushes information periodically to the NetFlow reporting collector. In general, the NetFlow cache is constantly filling with flows and software in the router or switch is searching the cache for flows that have terminated or expired and these flows are exported to the NetFlow collector server. Flows are terminated when the network communication has ended (ie: a packet contains the TCP FIN flag). The following steps are used to implement NetFlow data reporting:

- NetFlow is configured to capture flows to the NetFlow cache
- NetFlow export is configured to send flows to the collector
- The NetFlow cache is searched for flows that have terminated and these are exported to the NetFlow collector server
- Approximately 30 to 50 flows are bundled together and typically transported in UDP format to the NetFlow collector server
- The NetFlow collector software creates real-time or historical reports from the data

### **How Does the Router or Switch Determine Which Flows to Export to the NetFlow Collector Server?**

A flow is ready for export when it is inactive for a certain time (ie: no new packets received for the flow); or if the flow is long lived (active) and lasts greater than the active timer (ie: long FTP download). Also, the flow is ready for export when a TCP flag indicates the flow is terminated (i.e. FIN, RST flag). There are timers to determine if a flow is inactive or if a flow is long lived and the default for the inactive flow timer is 15 seconds and the active flow timer is 30 minutes. All the timers for export are configurable but the defaults are used in most cases except on the Cisco Catalyst 6500 Series Switch platform. The collector can combine flows and aggregate traffic. For example, an FTP download that lasts longer than the active timer may be broken into multiple flows and the collector can combine these flows showing total ftp traffic to a server at a specific time of day.

### What is the Format of the Export Data?

There are various formats for the export packet and these are commonly called the export version. The export versions are well documented formats including version 5, 7, and 9. The most common format used is NetFlow export version 5 but version 9 is the latest format and has some advantages for key technologies such as security, traffic analysis and multicast. To understand more about export versions and to read a detailed technical discussion about NetFlow, please see the NetFlow Services and Solutions Guide:

[http://www.cisco.com/en/US/products/sw/netmgtsw/ps1964/products\\_implementation\\_design\\_guid\\_e09186a00800d6a11.html](http://www.cisco.com/en/US/products/sw/netmgtsw/ps1964/products_implementation_design_guid_e09186a00800d6a11.html)

Figure 2 below is an example of the data available in a NetFlow cache.

**Figure 2.** Example NetFlow Cache

#### 1. Flow cache—The first unique packet creates a flow

SrcIf	SrcIPadd	DstIf	DstIPadd	Protocol	TOS	Flgs	Pkts	Src Port	Src Msk	Src AS	Dst Port	Dst Msk	Dst AS	NextHop	Bytes/Pkt	Active	Idle
Fa1/0	173.100.21.2	Fa0/0	10.0.227.12	11	80	10	11000	162	/24	5	163	/24	15	10.0.23.2	1528	1745	4
Fa1/0	173.100.3.2	Fa0/0	10.0.227.12	6	40	0	2491	15	/26	196	15	/24	15	10.0.23.2	740	41.5	1
Fa1/0	173.100.20.2	Fa0/0	10.0.227.12	11	80	10	10000	161	/24	180	10	/24	15	10.0.23.2	1428	1145.5	3
Fa1/0	173.100.6.2	Fa0/0	10.0.227.12	6	40	0	2210	19	/30	180	19	/24	15	10.0.23.2	1040	24.5	14

#### 2. Flow Aging Timers

- Inactive Flow (15 sec is default)
- Long Flow (30 min (1800 sec) is default)
- Flow ends by RST or FIN TCP Flag

SrcIf	SrcIPadd	DstIf	DstIPadd	Protocol	TOS	Flgs	Pkts	Src Port	Src Msk	Src AS	Dst Port	Dst Msk	Dst AS	NextHop	Bytes/Pkt	Active	Idle
Fa1/0	173.100.21.2	Fa0/0	10.0.227.12	11	80	10	11000	00A2	/24	5	00A2	/24	15	10.0.23.2	1528	1800	4

#### 3. Flows packaged in export packet

Non-aggregated Flows—Export Version 5 or 9

#### 4. Transport Flows to Reporting Server



### Where Can NetFlow be Implemented in the Network?

NetFlow is typically used on a central site because all traffic from the remote sites is characterized and is available within NetFlow. The location where NetFlow is deployed may depend on the location of the reporting solution and the topology of the network. If the reporting collection server is centrally located, then implementing NetFlow close to the reporting collector server is optimal. NetFlow can also be enabled at remote branch locations with the understanding that the export data will utilize bandwidth. About 1-5% of the switched traffic is used for export to the collection server.

**Figure 3.** NetFlow export to a collector

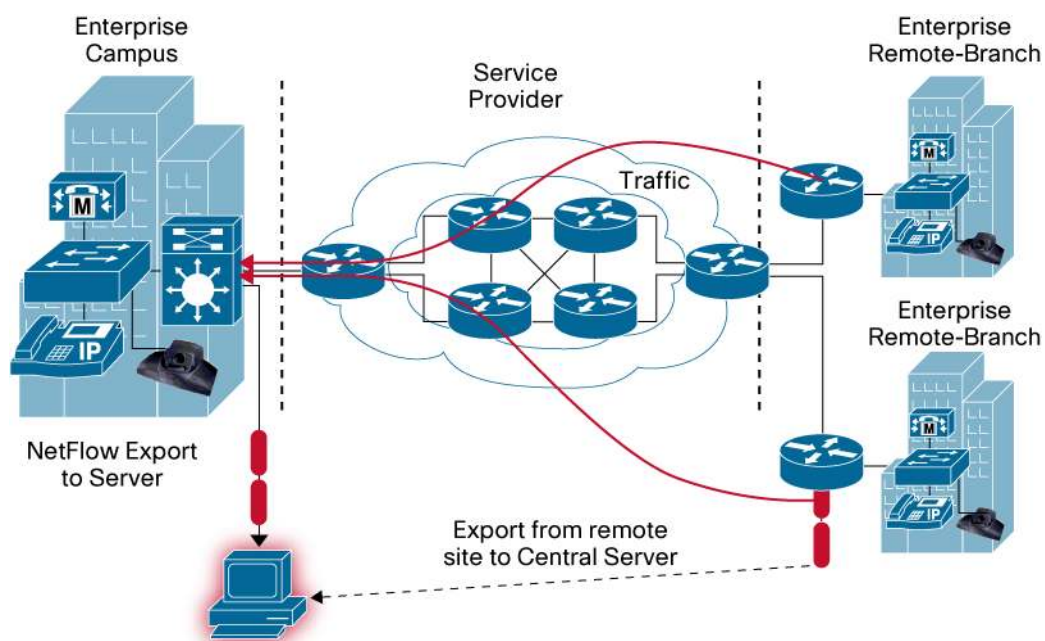

Almost all Cisco devices support NetFlow since its introduction in the 11.1 train of Cisco IOS Software and because of this, NetFlow is most likely available in any devices in the network.

**Table 1.** NetFlow Recent Cisco Device Support Matrix

Device	Supported
Cisco 800, 1700, 2600	Yes
Cisco 1800, 2800, 3800	Yes
Cisco 4500	Yes
Cisco 6500	Yes
Cisco 7200, 7300, 7500	Yes
Cisco 7600	Yes
Cisco 10000, 12000, CRS-1	Yes
Cisco 2900, 3500, 3660, 3750	No

## Which Applications Report on NetFlow Data?

There are a large number of NetFlow collectors including Cisco, freeware and third party commercial vendors' products that report and utilize NetFlow data. It is important to understand various factors when picking a partner for NetFlow reporting.

- What will be the main uses for NetFlow? Security, capacity planning and traffic analysis including application and user monitoring?
- Is real-time reporting or historical reporting more important?
- Which operating system is preferred for the server?
- Is this a large or small implementation of NetFlow and is scalability a concern?
- How much are you willing to pay for the product?
- Are there any current performance management products used in your organization and can these be extended to support NetFlow?

Once the reporting application is chosen, the sizing of the server and number of servers are determined by talking with the vendor for the product. Some reporting systems offer a two-tier architecture, where collectors are placed near key sites in the network and they aggregate and forward the data to a main reporting server. Other smaller deployments may have a single server for reporting and collection. Table 2 is a list of the Cisco NetFlow partner reporting products that are available, the operating system utilized and the main uses they offer. Also included are typical starting prices for the product with price ranges shown as low, medium, high. Low priced are for products that are less than \$7500, Medium ranged prices vary from \$7500 to \$25,000 and high priced greater than \$25,000. In recent years, many new partners and solutions are available on both Windows and Linux operating systems.

**Table 2.** Commercial NetFlow Reporting Products

Product Name	Primary Use	Primary User	Operating System	Starting Price Range
<a href="#">Cisco NetFlow Collector</a>	Traffic Analysis	Enterprise, Service Provider	Linux, Solaris	Medium
<a href="#">Cisco CS-Mars</a>	Security Monitoring	Enterprise, SMB	Linux	Medium
<a href="#">AdventNet</a>	Traffic Analysis	Enterprise, SMB	Windows	Low
<a href="#">Apoapsis</a>	Traffic Analysis	Enterprise	Linux	Medium
<a href="#">Arbor Networks</a>	Traffic/Security Analysis	Enterprise, Service Provider	BSD	High
<a href="#">Caligare</a>	Traffic/Security Analysis	Enterprise, Service Provider	Linux	Medium
<a href="#">Fluke Networks</a>	Traffic Analysis	Enterprise, SMB	Windows	Medium
<a href="#">CA Software</a> <sup>1</sup>	Traffic Analysis	Enterprise, Service Provider	Windows	High
<a href="#">Evident Software</a> <sup>1</sup>	Traffic Analysis, Billing	Enterprise	Linux	High
<a href="#">HP</a> <sup>1</sup>	Traffic Analysis	Enterprise, Service Provider	Linux, Solaris	High
<a href="#">IBM Aurora</a>	Traffic Analysis/Security	Enterprise, Service Provider	Linux	Medium
<a href="#">IdeaData</a>	Traffic Analysis	Enterprise	Windows/Linux	Medium

<sup>1</sup> Uses Cisco NetFlow Collector

Product Name	Primary Use	Primary User	Operating System	Starting Price Range
<a href="#">InfoVista</a>	Traffic Analysis	Enterprise, Service Provider	Windows	High
<a href="#">IsarNet</a>	Traffic Analysis	Enterprise, Service Provider	Linux	Medium
<a href="#">Lancope</a>	Traffic/Security Analysis	Enterprise, Service Provider	Linux	High
<a href="#">Micromuse</a> <sup>1</sup>	Traffic Analysis	Enterprise, Service Provider	Solaris	High
<a href="#">NetQoS</a>	Traffic/Security Analysis	Enterprise	Windows	High
<a href="#">Valencia Systems</a>	Traffic Analysis	Enterprise	Windows	High
<a href="#">Solarwinds</a>	Traffic Analysis	Enterprise, SMB	Windows	Low
<a href="#">Wired City</a>	Traffic Analysis	Enterprise	Windows	High

**Table 3.** Freeware NetFlow Reporting Products

Product Name	Primary Use	Comment	Operating System
<a href="#">CFlowd</a>	Traffic Analysis	No longer supported	Unix
<a href="#">Flow-tools</a>	Collector Device	Scalable	Unix
<a href="#">Flowd</a>	Collector Device	Supports V9	BSD, Linux
<a href="#">FlowScan</a>	Reporting for Flow-Tools		Unix
<a href="#">IPFlow</a>	Traffic Analysis	Support V9, IPv4, IPv6,MPLS, SCTP, etc.	Linux, FreeBSD, Solaris
<a href="#">NetFlow Guide</a>	Reporting Tools		BSD, Linux
<a href="#">NetFlow Monitor</a>	Traffic Analysis	Supports V9	Linux
<a href="#">NTOP</a>	Collector Device	Supports V9	Unix
<a href="#">Panoptis</a>	Security Monitoring		Unix
<a href="#">Stager</a>	Reporting for Flow-Tools		Unix

**Figure 4.** Example of traffic analysis reporting utilizing a NetFlow data

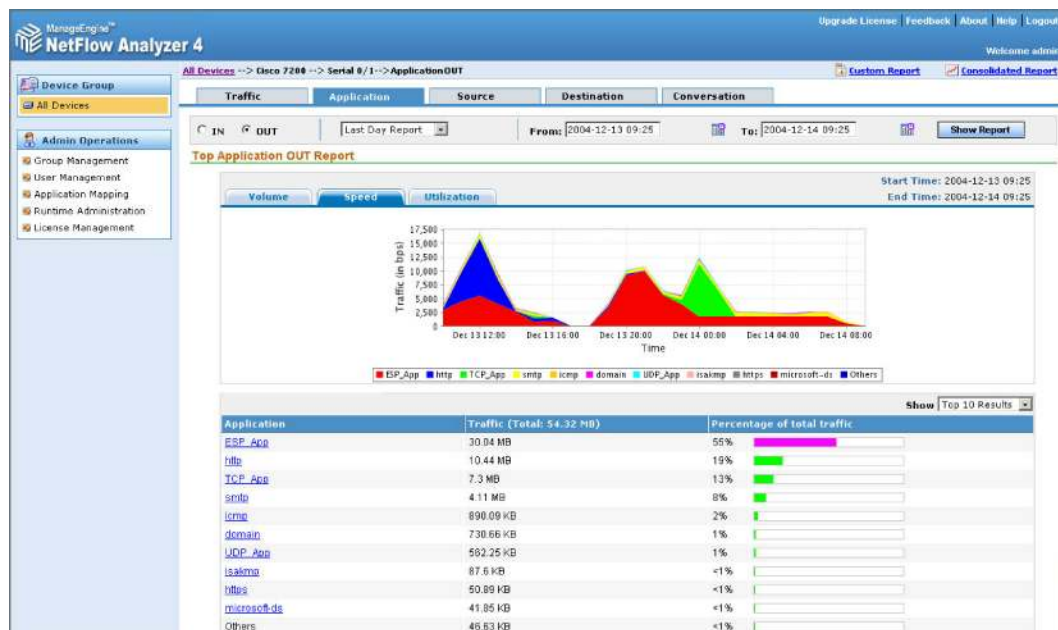

**Figure 5.** Example of CS-Mars Cisco product that utilizes NetFlow to understand security incidents

**Incident Graph-245738986**

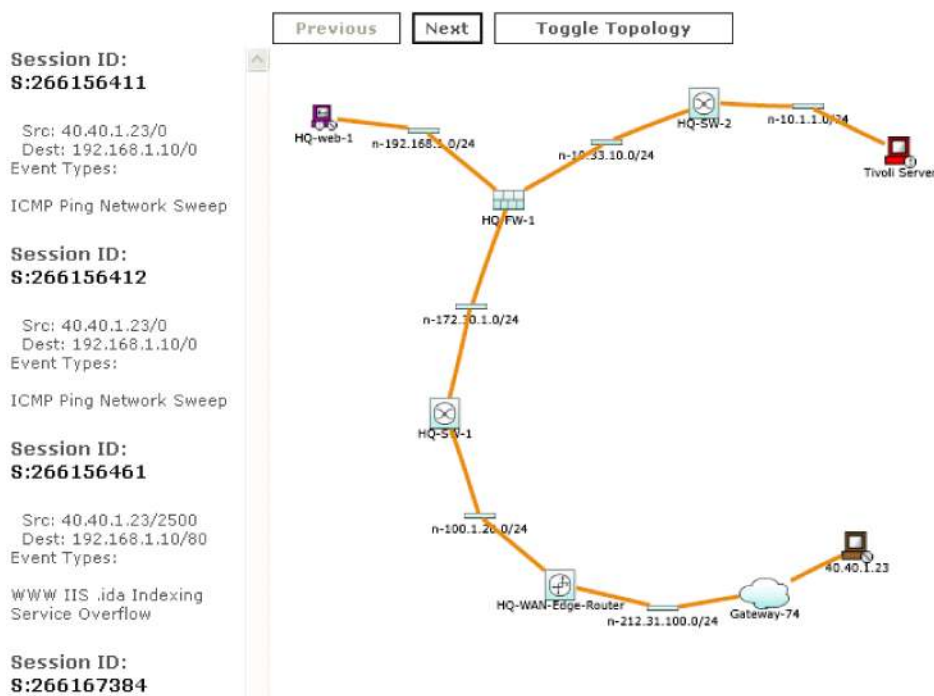

**Summary**

NetFlow is an important technology available in your Cisco device to help you with visibility into how your network assets are being used and the network behavior. NetFlow will help reduce costs by giving you an audit trail, reduce troubleshooting time and facilitate reports to understand network utilization. It will help in the implementation of new IP applications and detect security vulnerabilities. NetFlow will let you understand who is using the network, the destination of traffic, when the network is utilized and the type of applications consuming bandwidth.

For more information on NetFlow visit <http://www.cisco.com/go/netflow>.

For detailed technical IOS documentation on NetFlow, go to:

[http://www.cisco.com/en/US/products/ps6601/prod\\_white\\_papers\\_list.html](http://www.cisco.com/en/US/products/ps6601/prod_white_papers_list.html)

## Appendix A: Software Platform Configuration

The following is an example of a basic router configuration for NetFlow. NetFlow basic functionality is very easy to configure. NetFlow is configured on a per interface basis. When NetFlow is configured on the interface, IP packet flow information will be captured into the NetFlow cache. Also, the NetFlow data can be configured to export the NetFlow data to a collection server if a server is deployed.

1. Configuring the interface to capture flows into the NetFlow cache. CEF followed by NetFlow flow capture is configured on the interface

```
Router(config)# ip cef
Router(config)# interface ethernet 1/0 .
Router(config-if)# ip flow ingress
```

Or

```
Router(config-if)# ip route-cache flow
```

**Note:** Either ip flow ingress or ip route-cache flow command can be used depending on the Cisco IOS Software version. Ip flow ingress is available in Cisco IOS Software Release 12.2(15)T or above.

2. This step is required if exporting the NetFlow cache to a reporting server. The version or format of the NetFlow export packet is chosen and then the destination IP address of the export server. The 9997 is the UDP port the server will use to receive the UDP export from the Cisco device.

```
Router(config)# ip flow-export version 9
Router(config)# ip flow-export destination 172.22.23.7 9997
```

More Information on NetFlow Configuration is available at:

[http://www.cisco.com/en/US/products/ps6601/prod\\_white\\_papers\\_list.html](http://www.cisco.com/en/US/products/ps6601/prod_white_papers_list.html)

## Appendix B: Cisco Catalyst 6500 Series Switch Platform NetFlow Configuration

The following is an example of NetFlow on a Cisco Catalyst 6500 Series Switch. The Cisco Catalyst 6500 Series Switch has two aspects of NetFlow configuration, configuration of hardware based NetFlow and software NetFlow. Almost all flows on the Cisco Catalyst 6500 Series Switch are hardware switched and the MLS commands are used to characterize NetFlow in hardware. The MSFC (software based NetFlow) will characterize software based flows for packets that are punted up to the MSFC. Figure 8 shows the concept of two paths for NetFlow packets, the hardware and software paths and the configuration for each path. Normally on Cisco Catalyst 6500 Series Switch both hardware and software based NetFlow is configured.

**Figure 6.** NetFlow flow characterization on Cisco Catalyst 6500 Series Switch

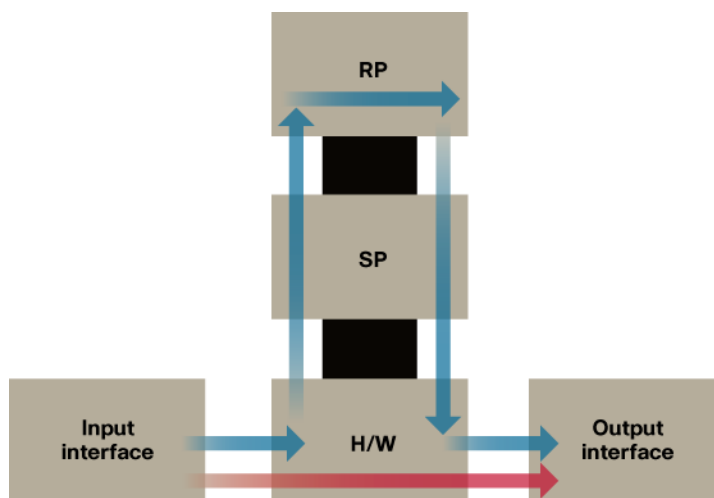

The hardware switched flows use the MLS commands to configure NetFlow. Remember for hardware based flows NetFlow is enabled on all interfaces when configured.

```
mls aging normal 32 (Set aging of inactive flows to 32 seconds)
mls flow ip interface-full (Optionally configure a flow mask)
mls nde sender version 5 (Specify the version for export from
the PFC)
mls nde interface (send interface information with the export, command
available by default with Supervisor720/Supervisor 32)
```

The following is the configurations for NetFlow on the MSFC for software based flows.

This configuration is equivalent to what is shown in Appendix A. The user configures NetFlow per interface to activate flow characterization and also configures an export destination for the hardware and software switched flows.

```
interface POS9/14
  ip address 42.50.31.1 255.255.255.252
  ip route-cache flow (also ip flow ingress can be used)
  ip flow-export version 5 (The export version is setup for the
software flows exported from the MSFC)
  ip flow-export destination 10.1.1.209 9999 (The destination for
hardware and software flows is specified).
```

More Information on the Cisco Catalyst 6500 Series Switch NetFlow Configuration can be viewed at: [http://www.cisco.com/en/US/products/ps6601/prod\\_white\\_papers\\_list.html#anchor7](http://www.cisco.com/en/US/products/ps6601/prod_white_papers_list.html#anchor7)

### Appendix C: Example Show Commands for NetFlow Data

The following is an example of how to visualize the NetFlow data using the CLI. There are three methods to visualize the data depending on the version of Cisco IOS Software. The traditional show command for NetFlow is “show ip cache flow” also available are two forms of top talker commands. One of the top talkers commands uses a static configuration to view top talkers in the network and another command called dynamic top talkers allows real-time sorting and aggregation of NetFlow data. Also shown is a show MLS command to view the hardware cache on the Cisco Catalyst 6500 Series Switch.

The following is the original NetFlow show command used for many years in Cisco IOS Software. Information provided includes packet size distribution; basic statistics about number of flows and export timer setting, a view of the protocol distribution statistics and the NetFlow cache.

```
R3#show ip cache flow
IP packet size distribution (469 total packets):
  1-32  64  96 128 160 192 224 256 288 320 352 384 416
448 480
  .000 .968 .000 .031 .000 .000 .000 .000 .000 .000 .000 .000 .000
.000 .000

      512 544 576 1024 1536 2048 2560 3072 3584 4096 4608
      .000 .000 .000 .000 .000 .000 .000 .000 .000 .000 .000

IP Flow Switching Cache, 278544 bytes
  7 active, 4089 inactive, 261 added
  1278 aged polls, 0 flow alloc failures
  Active flows timeout in 30 minutes
  Inactive flows timeout in 15 seconds
IP Sub Flow Cache, 25736 bytes
  1 active, 1023 inactive, 38 added, 38 added to flow
  0 alloc failures, 0 force free
  1 chunk, 1 chunk added
  last clearing of statistics never

Protocol      Total   Flows  Packets Bytes  Packets  Active(Sec)
Idle(Sec)
-----
Flows  /Sec  /Flow  /Pkt  /Sec  /Flow  /Flow
TCP-WWW      71     0.0    1     40    0.1    1.3    1.2
TCP-BGP      35     0.0    1     40    0.0    1.3    1.2
TCP-other   108     0.1    1     40    0.1    1.3    1.2
UDP-other    37     0.0    1     52    0.0    0.0   15.4
ICMP         3     0.0    5    100    0.0    0.0   15.3
Total:      254     0.2    1     42    0.4    1.1    3.5
```

(NetFlow cache below)

SrcIf	SrcIPAddress	DstIf	DstIPAddress	Pr	SrcP	DstP	Pkts
Et1/0	172.16.7.2	Null	224.0.0.9	11	0208	0208	1
Et1/0	172.16.10.2	Et0/0	172.16.1.84	06	0087	0087	1
Et1/0	172.16.10.2	Et0/0	172.16.1.84	06	0050	0050	1
Et1/0	172.16.10.2	Et0/0	172.16.1.85	06	0089	0089	1
Et1/0	172.16.10.2	Et0/0	172.16.1.85	06	0050	0050	1
Et1/0	172.16.10.2	Et0/0	172.16.1.86	06	00B3	00B3	1
Et1/0	172.16.10.2	Et0/0	172.16.1.86	06	0185	0185	2

Table 4.

Field	Description
<b>bytes</b>	Number of bytes of memory used by the NetFlow cache.
<b>active</b>	Number of active flows in the NetFlow cache at the time this command was entered.
<b>inactive</b>	Number of flow buffers that are allocated in the NetFlow cache, but were not currently assigned to a specific flow at the time this command was entered.
<b>added</b>	Number of flows created since the start of the summary period.
<b>ager polls</b>	Number of times the NetFlow code looked at the cache to cause entries to expire (used by Cisco for diagnostics only).
<b>flow alloc failures</b>	Number of times the NetFlow code tried to allocate a flow but could not.
<b>exporting flows</b>	IP address and User Datagram Protocol (UDP) port number of the workstation to which flows are exported.
<b>flows exported in udp datagrams</b>	Total number of flows exported and the total number of UDP datagrams used to export the flows to the workstation.
<b>failed</b>	Number of flows that could not be exported by the router because of output interface limitations.
<b>last clearing of statistics</b>	Standard time output (hh:mm:ss) since the clear ip flow stats privileged EXEC command was executed. This time output changes to hours and days after the time exceeds 24 hours.
<b>Protocol</b>	IP protocol and the well-known port number. (Refer to <a href="http://www.iana.org">http://www.iana.org</a> , Protocol Assignment Number Services, for the latest RFC values.) <b>Note:</b> Only a small subset of all protocols is displayed.
<b>Total Flows</b>	Number of flows in the cache for this protocol since the last time the statistics were cleared.
<b>Flows/Sec</b>	Average number of flows for this protocol per second; equal to the total flows divided by the number of seconds for this summary period.
<b>Packets/Flow</b>	Average number of packets for the flows for this protocol; equal to the total packets for this protocol divided by the number of flows for this protocol for this summary period.
<b>Bytes/Pkt</b>	Average number of bytes for the packets for this protocol; equal to the total bytes for this protocol divided by the total number of packets for this protocol for this summary period.
<b>Packets/Sec</b>	Average number of packets for this protocol per second; equal to the total packets for this protocol divided by the total number of seconds for this summary period.
<b>Active(Sec)/Flow</b>	Number of seconds from the first packet to the last packet of an expired flow divided by the number of total flows for this protocol for this summary period.
<b>Idle(Sec)/Flow</b>	Number of seconds observed from the last packet in each nonexpired flow for this protocol until the time at which the show ip cache verbose flow command was entered divided by the total number of flows for this protocol for this summary period.
show ip cache flow Field Descriptions in NetFlow Record Display	
<b>Field</b>	Description
<b>SrcIf</b>	Interface on which the packet was received.
<b>Port Msk AS</b>	Source Border Gateway Protocol (BGP) autonomous system. This is always set to 0 in MPLS flows.

Field	Description
<b>SrcIPAddress</b>	IP address of the device that transmitted the packet.
<b>DstIf</b>	Interface from which the packet was transmitted. <b>Note:</b> If an asterisk (*) immediately follows the DstIf field, the flow being shown is an egress flow.
<b>Port Msk AS</b>	Destination BGP autonomous system. This is always set to 0 in MPLS flows.
<b>DstIPAddress</b>	IP address of the destination device.
<b>NextHop</b>	Specifies the BGP next-hop address. This is always set to 0 in MPLS flows.
<b>Pr</b>	IP protocol well-known port number as described in RFC 1340, displayed in hexadecimal format.
<b>B/Pk</b>	Average number of bytes observed for the packets seen for this protocol (total bytes for this protocol or the total number of flows for this protocol for this summary period).
<b>Flgs</b>	TCP flags (result of bitwise OR of TCP flags from all packets in the flow).
<b>Active</b>	Number of active flows in the NetFlow cache at the time this command was entered.
<b>Pkts</b>	Number of packets switched through this flow.

More information on show ip cache flow is available at:

[http://www.cisco.com/en/US/products/ps6350/products\\_command\\_reference\\_chapter09186a0080443cb7.html#wp1306767](http://www.cisco.com/en/US/products/ps6350/products_command_reference_chapter09186a0080443cb7.html#wp1306767)

The following command will show hardware based flow specifically on the Cisco Catalyst 6500 Series Switch platform. Also, the above command “show ip cache flow” can be used to show both hardware and software flows on the Cisco Catalyst 6500 Series Switch but this depends on the supervisor and release of Cisco IOS Software being used.

```
C6500#show mls netflow ip
Displaying Netflow entries in Supervisor Earl
DstIP          SrcIP          Prot:Src Port:DstPort  Src i/f
:AdjPtr Pkts          Bytes          Age   LastSeen  Attributes
-----
10.102.130.213 10.214.39.79   tcp:46528      :www      :0x0 7
3766          17    15:47:37   L3 - Dynamic
10.230.215.148 10.155.22.221  tcp:51813      :45912    :0x0 25
21329         47    15:47:39   L3 - Dynamic
10.97.36.200   10.17.64.177  tcp:65211      :www      :0x0 9
7664          17    15:47:38   L3 - Dynamic
10.90.33.185   10.46.13.211  tcp:27077      :60425    :0x0 10
5734          17    15:47:38   L3 - Dynamic
<...>
```

The following describes the NetFlow Top Talkers command showing the largest packet and byte consumers on the network. Network Top Talkers does require some configuration. The configuration is shown followed by the show command. This command is available in Release 12.3(11)T and Release 12.2(25)S and above Cisco IOS Software releases.

```
Router(config)#ip flow-top-talkers
Router(config-flow-top-talkers)#top 10
```

The following is the 10 ten talkers in network sorted by packets:

```
R3#show ip flow top-talkers
```

SrcIf	SrcIPaddress	DstIf	DstIPaddress	Pr	SrcP	DstP	Pkts
Et1/0	172.16.10.2	Et0/0	172.16.1.84	06	0087	0087	2100
Et1/0	172.16.10.2	Et0/0	172.16.1.85	06	0089	0089	1892
Et1/0	172.16.10.2	Et0/0	172.16.1.86	06	0185	0185	1762
Et1/0	172.16.10.2	Et0/0	172.16.1.86	06	00B3	00B3	2
Et1/0	172.16.10.2	Et0/0	172.16.1.84	06	0050	0050	1
Et1/0	172.16.10.2	Et0/0	172.16.1.85	06	0050	0050	1

7 of 10 top talkers shown. 7 flows processed.

More information on NetFlow MIB and Top Talkers can be found at:

[http://www.cisco.com/en/US/products/sw/iosswrel/ps1838/products\\_feature\\_guide09186a0080259533.html](http://www.cisco.com/en/US/products/sw/iosswrel/ps1838/products_feature_guide09186a0080259533.html)

The following command shows the output of the Dynamic Top Talkers command to show all flows to a specific destination address. This command was released in Release 12.4(4)T. This command is very useful to search the NetFlow cache in various methods and sorting by number of flows, packets or bytes. This command is very useful for troubleshooting and on the real-time security monitoring.

```
R3#show ip flow top 10 aggregate destination-address
There are 3 top talkers:
```

IPV4 DST-ADDR	bytes	pkts	flows
172.16.1.86	160	4	2
172.16.1.85	160	4	2
172.16.1.84	160	4	2

This following is an example of the Dynamic Top Talker command with the sorting of all flows to a specific destination on a port range

```
R3#show ip flow top 10 aggregate destination-address sorted-by bytes
match source-port min 0 max 1000
```

There are 3 top talkers:

IPV4 DST-ADDR	bytes	pkts	flows
172.16.1.84	80	2	2
172.16.1.85	80	2	2
172.16.1.86	80	2	2

6 of 6 flows matched.

Other Examples include:

- Top 10 protocols currently flowing through the router:  
`router# show ip flow top 10 aggregate protocol`
- Top 10 IP addresses which are sending the most packets:  
`router# show ip flow top 10 aggregate source-address sorted-by packets`
- Top 5 destination addresses to which we're routing most traffic from the 10.0.0.1/24 prefix:  
`router# show ip flow top 5 aggregate destination-address match source-prefix 10.0.0.1/24`
- 50 VLAN's which we're sending the least bytes to:  
`router# show ip flow top 50 aggregate destination-vlan sorted-by bytes ascending`
- Top 20 sources of 1-packet flows:  
`router# show ip flow top 50 aggregate source-address match packets 1`

More information on Dynamic Top Talkers can be found at:

- Detecting and Analyzing Network Threats with NetFlow  
[http://www.cisco.com/en/US/products/ps6441/products\\_configuration\\_guide\\_chapter09186a008055404a.html](http://www.cisco.com/en/US/products/ps6441/products_configuration_guide_chapter09186a008055404a.html)



**Americas Headquarters**  
 Cisco Systems, Inc.  
 170 West Tasman Drive  
 San Jose, CA 95134-1706  
 USA  
[www.cisco.com](http://www.cisco.com)  
 Tel: 408 526-4000  
 800 553-NETS (6387)  
 Fax: 408 527-0689

**Asia Pacific Headquarters**  
 Cisco Systems, Inc.  
 155 Robinson Road  
 #29-01 Capital Tower  
 Singapore 068912  
[www.cisco.com](http://www.cisco.com)  
 Tel: +65 6317 7777  
 Fax: +65 6317 7799

**Europe Headquarters**  
 Cisco Systems International BV  
 Heerlenbergpark  
 Heerlenbergweg 13-19  
 1101 CH Amsterdam  
 The Netherlands  
[www.europe.cisco.com](http://www.europe.cisco.com)  
 Tel: +31 0 20 620 0791  
 Fax: +31 0 20 657 1100

Cisco has more than 200 offices worldwide. Addresses, phone numbers, and fax numbers are listed on the Cisco Website at [www.cisco.com/go/offices](http://www.cisco.com/go/offices).

©2007 Cisco Systems, Inc. All rights reserved. CCVP, the Cisco logo, and the Cisco Square Bridge logo are trademarks of Cisco Systems, Inc.; Changing the Way We Work, Live, Play, and Learn is a service mark of Cisco Systems, Inc.; and Access Registrar, Aironet, BPK, Catalyst, CCNA, CCDP, CCIE, CCR, CCNA, CCNP, CCSP, Cisco, the Cisco Certified Internetwork Expert logo, Cisco IOS, Cisco Press, Cisco Systems, Cisco Systems Capital, the Cisco Systems logo, Cisco Unity, Enterprise/Solver, EtherChannel, EtherFast, EtherSwitch, Fax, Step, Follow Me Browsing, FormShare, Go to Drive, HomeLink, Internet Quotient, IOS, IPPhone, IPTV, IQ Expertise, the IQ logo, IQ Notepad, Roadnote, Scorecard, QuickStudy, SignStream, iInlays, MeetingPlace, MGX, Networking Academy, Network Registrar, Packet, PIX, ProConnect, ScriptShare, SMARTnet, SsookWise, The Fastest Way to Increase Your Internet Quotient, and TransPath are registered trademarks of Cisco Systems, Inc. and/or its affiliates in the United States and certain other countries.

All other trademarks mentioned in this document or Website are the property of their respective owners. The use of the word partner does not imply a partnership relationship between Cisco and any other company. (9705R)